

AC/DC CUSTOM-MADE SOLUTIONS



Fully Automatic Voltage and Current Regulated Battery Charger

Switchgear Closing Tripping • Emergency Lighting • Telecommunications • Control and Monitoring Systems • Microwave Links and Radio Installations • Fire and Security Systems

Introduction

The name Chloride is synonymous with batteries.... with quality and dependability proved and improved since the 19 century.

This Chloride experience has been extended to battery chargers of standby power battery systems (i.e. batteries used in fixed locations). It is specially designed to meet the vital requirements of standby power system batteries.

Chloride Batteries' series of standby power system chargers are built for both lead acid and nickel cadmium batteries. They are available in single or three phase units, depending on input power ratings. Indeed, it has incorporated the most asked-for features and offers a high degree of standardization and reliability, such as:

- Complete automatic operations and designed for easy maintenance and longer battery life.
- Solid state circuitry that constantly monitors battery conditions. Fully automatic boost and float charge functions that ensure maximum battery life and a 100% rating in battery performance.
- A phase controlled thyristor rectifier generously derated for a longer reliable life cycle.
- Low-impedance leakage reactance transformer that provides inherent short circuit protection for rectifiers and reduces the peak current applied to batteries.
- A 'soft start' feature to provide sufficient time for limited current to operate on start up even under short circuit conditions. An additional benefit is a complete "soft start" resetting on rapid Mains re-application which may occur in transient line-fault conditions.
- D.C. output protected by fuses ensure correct circuit protection against overloads.
- Transformers, controller card and thyristors are in common circuit configuration and standardized throughout the entire range of standby power system chargers. This makes it convenience to replace parts and minimizes down-time.
- Controller cards are completely interchangeable, ensuring spare parts are readily and constantly available.
- Optional cubicles are available; to accommodate only the charger; both charger and battery, or upon request; custom-made 19-inch rack-mounted.
- Instruments, controls and indicators are conveniently grouped for ease of operation.
- Alarm sensing device is fitted as standard equipment to monitor the respective functions:
 - a) A.C. ON
 - b) Boost charge
 - c) Float charge
 - d) Charge failure
 - e) Low battery voltage
 - f) High battery voltage
 - g) Electrolyte low level
 - h) Faulty earthed
- Labelled L.E.D. indicators fitted to the control panel to show individual local faults.
- Fault indicators are maintained until the fault has been cleared and the alarm automatically reset. Manual resetting is also available.
- Remote or local audible alarm indication of common fault conditions are made possible through a set of voltage free changeover contacts, on a relay fitted to the control card.
- Adjustable high and low voltage alarm levels to suit each application.



Single-Phase Charger

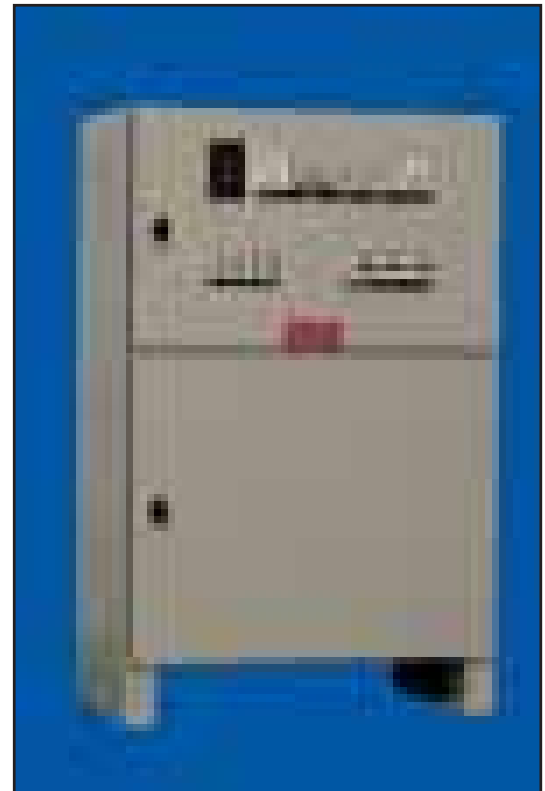

Small Charger

Technical Specifications

CBC-4 Charger

The CBC-4 charger operates from a single-phase supply. It incorporates a single phase full wave thyristor/diode rectifier, that operates as a phase controlled regulator.

3-CBC-4 Charger

The 3-CBC-4 charger operates from a three-phase 4 wire supply. It incorporates a three phase six pulse fully controlled thyristor rectifier, to minimize both low A.C. input current harmonic distortion and D.C. output ripple current.

Both types of charger circuits act as a constant voltage current-limit regulator, providing D.C. output current and voltage regulation in either the constant current or constant voltage modes. Given a fully charged battery under normal operating conditions, the Chloride Batteries standby power system chargers operate as a constant voltage charger, current limit type at float voltage level. This is adjusted to maintain battery in a fully charged state with minimal over-charging and water consumption. The CBC-4 charger is capable of recharging battery within 16 hours following the battery's discharge specifications.

A constant current boost charge is initiated automatically under the following conditions:-

- 1) Restoration of mains supply.
- 2) Battery voltage less than 90% of float voltage.
- 3) Momentary operation of the A.C. circuit breaker

Manual boost selection is also possible by momentarily interrupting the A.C. supply to the charger. There are two scenarios in which boost charge is automatically terminated and float charge initiated:

- a) Charged Battery Prior to Boost Initiation - The battery voltage rises to approximately 90% of the preset boost voltage level within a set time, typically in 30 minutes.
- b) Fully/Partially Discharged Battery Prior to Boost Initiation - If battery does not rise to 90% level within the set time, the boost continues under voltage control, until the battery's voltage reaches 90% level. At this point, a solid state timer is activated to control boost charge for a preset time to complete the charge.

Tolerance

Boost and Float charge voltages and output currents are set at the recommended levels according to battery specification.

Voltage Regulation

Adjustment controls, mounted on charger, prevent unauthorized interference. Float and Boost voltages held at preset level +/- 1%, at the battery terminal allows simultaneous changes in mains input voltage of +/- 5% to 10% and load variations 0% to 100% (24 volts systems and above).

Current Regulation

Output current held at preset level +/- 0.5%, allows simultaneous changes in the mains input voltage of +5% to -10% and battery voltage variations from 50% to 100% of boost charge level.

Charge Ammeter and Voltmeter

Industrial Grade with a 2.5% accuracy. Core magnet with self-shielding movement. The instruments are :

- i) Charger Output Current
- ii) Battery Voltage

Indicators

Individual light emitting diode (L.E.D) lamps provide indications:

For Function Monitors :-

- A.C. input
- Boost charge
- Float charge

For Fault Monitors :-

- Charge failure
- Low battery volts
- High battery volts
- Low battery electrolyte
- Earth Fault
- Provisions for remote common fault indicators via a set of voltage-free changeover contacts on a relay fitted to the control charge.

Fault Monitoring

Fault LEDs remain illuminated when a fault condition exist. It will automatically reset only when the fault is cleared. A set of voltage



Hybrid
Thyristor Rectifier



Transformer



Controller
Card

free changeover contact relays can be provided for remote monitoring of the common fault conditions.

Charge Fail Alarm

Charge fail alarm circuit is designed to operate only when there is no current flow to battery and battery voltage is below 90% of preset Float level.

Low Electrolyte Alarm

The Low Electrolyte alarm circuit is designed to operate when the battery electrolyte falls to the minimum level prescribed by the battery manufacturer. The inserted low electrolyte sensing probe place in the battery will sense an "open" circuit when the battery electrolyte loses contact with the probe at its minimum level, thus, triggering an alarm.

Transformer

Leakage reactance, double wound and varnish impregnated to BS standard. Temperature class 'F' electro-static earth shield between primary and secondary control windings. Impedance : Single-phase typically at 25% and Three-phase typically at 10%.

Rectifier

Thyristor rectifier assembly is heat-sink mounted and derated by 50% at full load output.

Smoothing

i) Single-phase Units:

Ripple voltage at 5% R.M.S. average at full load.

Ripple current less than 15% battery's ampere-hour capacity at a 10-hour rating.

ii) Three-phase Units:

Ripple voltage at 3% R.M.S. average at full load.

Ripple current less than 15% battery's ampere-hour capacity at a 10-hour rating.

Technical Specifications

Electrical Protection

A.C. input : Thermal-magnetic circuit breaker.

Current Limit

Solid state, limiting to 100% of full load current for protection upto short circuit conditions. Enables charger to supply regulated current at a reduced battery voltage.

Surge Suppression

Metal Oxide Varistor connected across primary side of the transformer to provide protection against A.C. line transients.

Pre-Delivery Testing

Each unit is fully tested and inspected prior to delivery. This is to ensure that all circuitry functions are operating correctly and no premature component malfunction occurs during operation.

Ambient Rating

Units are designed for continuous full load operations, up to 45°C ambient temperatures.

DC OUTPUT	INPUT	INPUT
Nominal D.C. Volts	220 TO 250V (1 Phase, 2 Wire)	380 to 415V (3 Phase, 4 Wire)
Range	D.C. Output Amps	D.C. Output Amps
12 Volts	1 to 60 Amps	-
24 Volts	1 to 60 Amps	75 to 150 Amps
32 Volts	1 to 60 Amps	75 to 150 Amps
48 Volts	1 to 60 Amps	75 to 150 Amps
110 Volts	1 to 60 Amps	75 to 150 Amps
220 Volts	1 to 20 Amps	1 to 60 Amps

Note : Non-standard available on request.

Manufacturing Standards

- * All chargers are designed and manufactured to in-housed specification which uses components that conforms to IEC Standards.
- * Naturally cooled.
- * Meters are 72 x 72, 90° scale-type with an option for 2.5 or 1.5.
- * Control and power circuits wiring are >1.5mm sq.
- * Printed circuit connections are by ribbon-cable at 0.9mm sq.
- * Wire marking by ferrules (wire-wire).
- * All main components are accessible through the front-panel door.
- * Main components on front-panel door are identified with black and white labels, engraved with English words.
- * Main components inside the cubicle are also clearly identified.
- * Terminals are positioned at the base or side of cubicle, to provide for easy entry of cables.
- * Engraving labels are provided to describe the function of all controls, instruments, monitoring lamps, and protective devices. Labels will be secured to the charger with double-sided tape.

Reference Standards:

	IEC
Semi conductor converters	146
Degree of Protection	529
Power Transformers	76
Switchgear - Contactors	158
- Circuit Breakers	157
- Low Voltage Switches	408
- Fuses	269
Wires - Cables	227
Measuring Instruments	51
Rectifiers	146

Single-Phase Chargers - 230 Volt

Input

The charger is suitable for operations from a 230-volt +5% to -10%, 50Hz +/- 2%, single phase two wire supply.

Smoothing

Ripple voltage is limited to better than 5% RMS average at full load. The alternating current component in the battery circuit shall be limited to less than 15% of the battery's ampere hour capacity at a 10-hour rate of discharge.

Protection

The following protective devices are provided:

- * A single-pole thermal magnetic circuit breaker in the charger's A.C. input line.
- * HRC fused wire in the D.C. Negative's output lines between the rectifier and the battery.
- * Surge suppression for protection against A.C. line voltage transients.
- * Solid state current limiting to limit output to 100% of full load and provides protection even in short circuit conditions.

Charger Without Battery

Cubically-designed for floor or wall-mounted and fitted with single-braced door and full length piano-type hinge door with key-lock devices. The instruments controls and indicators are mounted on the front-door panel.

Charger With Battery

Cubically-designed and free standing, with charger in the top section and battery in the bottom section. Door-panels are fitted with full length piano-type hinge with key-lock devices.

Control Panel

The control panel is 1.2mm thick and accommodates all instruments controls and indicators.

Battery Shelves

Multi-tiered and full-width battery shelves allows electrolyte levels of all cells to be visible. It also allows routine maintenance to be carried out, without the need to remove battery cells.



Single-Phase Charger

Single-Phase Chargers - 230 Volt

Cubicles

All chargers' cubicles are manufactured from folded and welded electro-galvanized steel sheet greater than 1.2mm in thickness.

Ventilation

Drip-proof pressed louvres are provided on both sides of the cubicle to ensure that adequate ventilation is achieved in the charger as well as in the battery compartment.

Cable Entry Holes

Three 26mm diameter cables entry holes are provided on each side of the charger's section of the cubicle.

Finishing

All spot welds are grounded smooth, metal work abrasive-cleaned as well as phosphate cleaned and etched out. The interior and exterior surfaces are protected by an application of electrolyte resistant coating. Standard colours are in beige or light grey.

Three-Phase Chargers - 400 Volt

Input

The charger is suitable for operation by a 400 to 440 volt +5% to -10%, 50 Hz +/-2%, three phase four wire supply.

Smoothing

Ripple voltage is limited to 3% RMS average at full load. The alternating current components in the battery circuit are limited to less than 15% of the battery's ampere-hour capacity, at a 10-hour rate of discharge.

Protection

The following protective devices are provided:-

- * Triple pole thermal magnetic circuit breaker in the charger AC input lines.
- * HRC fused wire in DC positive/negative output lines between the rectifier and the battery.
- * Surge suppression for protection against AC line voltage transients.
- * Solid state current limiting to limit output to 100% of full load and provides protection even in short circuit conditions.
- * Phase sequence protection relay interlocks with the control circuit.
- * Resistor/capacitor network connected in parallel with each thyristor.

Charger Without Battery

Cubically-designed and free standing for floor or wall-mounting, and fitted with a single-braced door and full length piano-type hinge door with key-lock devices. All instrument controls and indicators are mounted on the door-panel.

Cubicle

Cubicles are manufactured from folded and welded electro-galvanized steel sheet greater than 1.2mm in thickness.

Ventilation

Drip proof pressed-louvres on both sides of cubicle ensure adequate ventilation.

Cable Entry

A removable gland plate is provided on the top and bottom panels of each cubicle.

Finishing

All spot welds are grounded smooth, and metal work abrasive-cleaned, as well as phosphate cleaned and etched out. The interior and exterior surfaces are protected by application of an electrolyte resistant coating. Standard colours are in beige or light grey.



Three-Phase Charger



Three-Phase Charger

Optional Extras

Smoothing

Average 1% R.M.S. for inverter/communication applications.

D.C. Load Circuit Protection

Standard ratings used in the thermal magnetic breakers for both single or double pole configurations. Numbered negative link is provided when used in single pole configuration. Double pole breakers are provided for applications of 110 volts and above.

NOTE: A battery state-of-charge test is not required as the charger automatically recharges after a discharge and/or restoration to the mains.

The panel mounted voltmeter indicates the battery's conditions during charging and discharging.

Individual Remote Alarm Monitoring

Alarm card provides for individual remote indicators for monitoring faulty conditions via a set of voltage-free changeover contacts.

- | | |
|--------------------|----------------|
| 1) A.C. on | 5) High Volts |
| 2) Boost | 6) Low Volts |
| 3) Float | 7) Earth Fault |
| 4) Low Electrolyte | 8) Charge Fail |

Single-Phase Circuit Diagrams

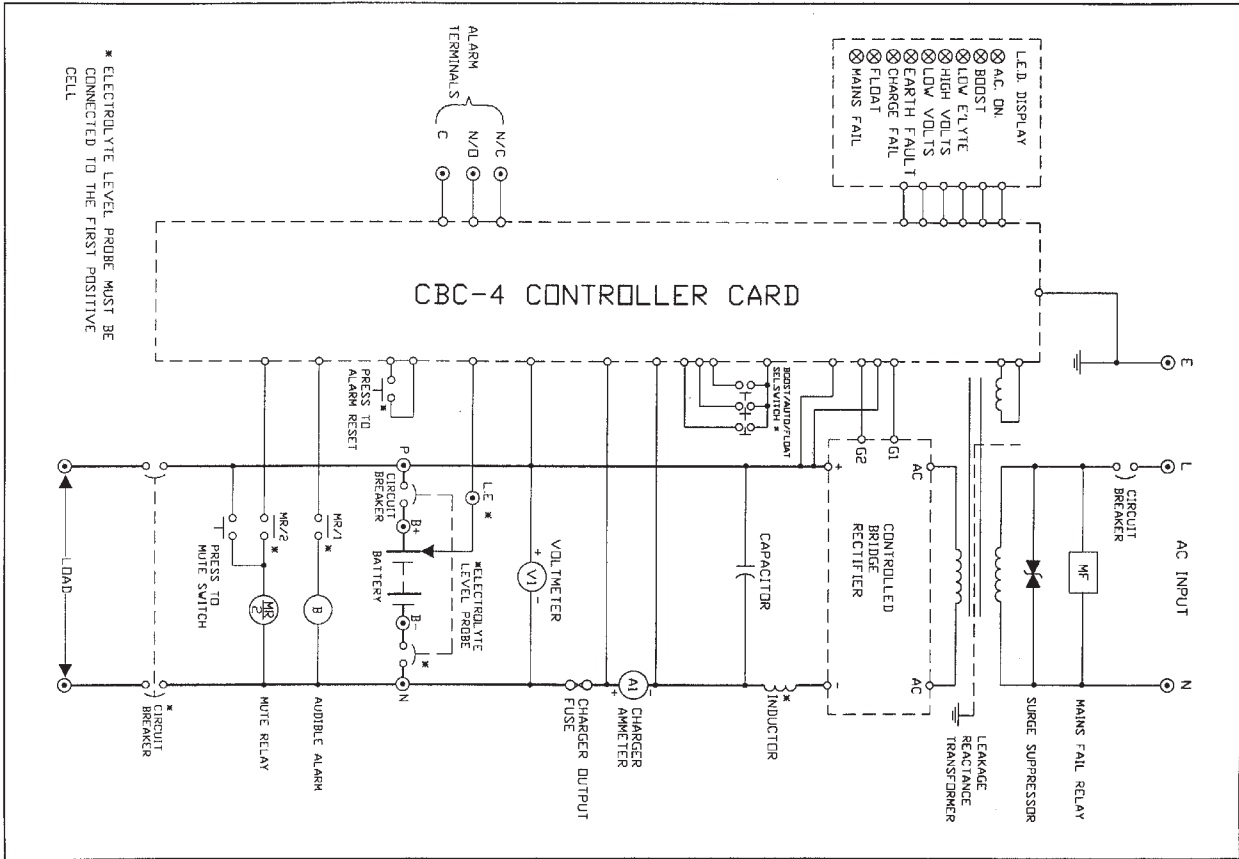

Three-Phase Circuit Diagrams

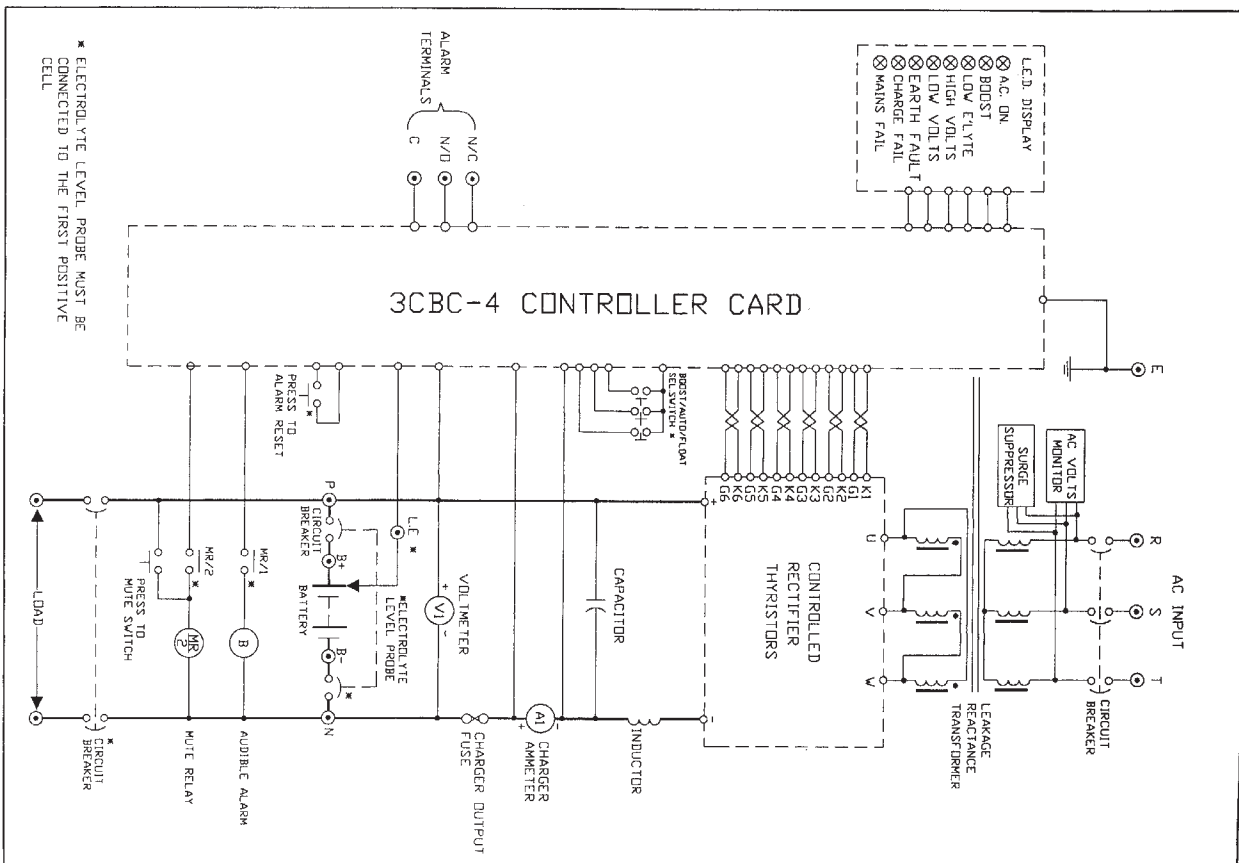

Technical Specifications

Single-Phase

Model No	Input Current	Chassis Plate		Approx.	Recommended
	AT 220V	W	D	WR (KG)	Cabinet
CBC12/5	0.6	300	500	20	41
CBC12/10	1.2	300	500	25	41
CBC12/15	1.9	300	500	30	41
CBC12/20	2.6	380	500	50	43A
CBC12/30	3.8	380	500	58	43A
CBC12/40	5.0	380	500	65	43A
CBC12/50	6.4	380	500	70	43A
CBC12/60	7.7	380	500	78	43A
CBC24/5	1.0	300	500	25	41
CBC24/10	2.6	300	500	40	41
CBC24/15	4.0	300	500	45	41
CBC24/20	5.0	380	500	52	43A
CBC24/25	6.0	380	500	60	43A
CBC24/30	8.0	380	500	65	43A
CBC24/40	10.0	380	500	75	43A
CBC24/50	13.0	380	500	80	43A
CBC24/60	15.0	380	500	90	42A
CBC24/70	18.0	500	800	100	42A
CBC24/80	20.0	500	800	110	42A
CBC24/100	26.0	500	800	120	42A
CBC30/5	1.0	300	500	28	41
CBC30/10	3.0	300	500	42	41
CBC30/15	5.0	380	500	48	43A
CBC30/20	6.0	380	500	60	43A
CBC48/5	2.6	380	500	40	43A
CBC48/10	5.0	380	500	45	43A
CBC48/15	7.7	380	500	55	43A
CBC48/20	10.3	380	500	70	43A
CBC48/30	15.4	380	500	80	43A
CBC48/40	20.6	500	800	90	42A
CBC48/50	25.7	500	800	100	42A
CBC48/60	30.9	500	800	110	42A
CBC48/70	36.0	500	800	120	42A
CBC48/80	41.0	500	800	130	42A
CBC110/5	5.8	380	500	45	43A
CBC110/10	11.7	380	500	70	43A
CBC110/20	23.5	380	500	90	43A
CBC110/30	35.3	500	800	110	42A
CBC110/40	47.1	500	800	130	42A
CBC110/50	58.9	500	1200	160	42M
CBC110/60	70.7	500	1200	180	42M
CBC220/5	11.5	500	800	70	42A
CBC220/10	23.6	500	800	90	42A
CBC220/15	35.4	500	800	105	42A
CBC220/20	47.0	500	800	130	42A

Three-Phase

Model No	Input Current	Chassis Plate		Approx.	Recommended
	AT 415V	W	D	WR (KG)	Cabinet
3CBC24/60	4.7	500	800	70	42A
3CBC24/80	6.3	500	800	100	42A
3CBC24/100	7.8	500	1200	130	42M
3CBC24/120	9.4	600	1500	150	H1900
3CBC24/150	11.0	600	1500	180	H1900
3CBC24/200	12.2	600	1500	220	H1900
3CBC48/30	4.7	500	800	70	42A
3CBC48/40	6.3	500	800	80	42A
3CBC48/50	7.8	500	800	90	42A
3CBC48/60	9.4	500	1200	110	42M
3CBC48/80	12.5	500	1200	130	42M
3CBC48/100	15.6	600	1500	150	H1900
3CBC48/120	17.0	600	1500	180	H1900
3CBC48/150	19.5	600	1500	210	H1900
3CBC48/200	26.0	600	1500	260	H1900
3CBC110/15	5.4	500	800	70	42A
3CBC110/30	10.7	500	1200	110	42M
3CBC110/40	14.3	500	1200	130	42M
3CBC110/50	16.0	600	1500	150	H1900
3CBC110/60	21.5	600	1500	180	H1900
3CBC110/80	28.7	600	1500	220	H1900
3CBC110/100	35.8	600	1500	260	H1900
3CBC110/150	46.0	600	1500	320	H1900
3CBC110/200	61.0	600	1500	320	H1900
3CBC220/10	3.5	500	800	90	42A
3CBC220/20	7.1	500	1200	130	42M
3CBC220/40	14.1	600	1500	220	H1900
3CBC220/50	28.0	600	1500	260	H1900
3CBC220/60	33.6	600	1500	300	H1900
Cabinet Type	Height	Width	Depth		
41	400	460	260		
43A	890	500	370		
42A	1290	600	520		
42M	1590	600	520		
H1900	1900	840	800		

AC/DC CUSTOM-MADE SOLUTIONS

CHLORIDE

For further information, please contact our local agent or distributor:

CHLORIDE BATTERIES S.E. ASIA PRIVATE LIMITED

106 Neythal Road, Jurong Town, Singapore 628594.

Tel : (65) 6265 2444 Fax : (65) 6265 1478

Email: chloride@cbsea.com.sg

Website: www.cbsea.com.sg

In line with our policy of continuous improvement, we reserve the right to change product specifications and design without notice.
We shall not be liable for any claims to any damage or injury if products are not used in accordance with operational instructions provided.
The user is responsible for obtaining updated and current technical specifications and technical information.